



### Approval Marks



- LWDC40W1050NLR-W
- LWDC40W1050NLR-B
- LWDC40W1050NLR-G



Item	Value	Remark
Nominal voltage	220–240V	
Nominal frequency	50–60Hz	
AC voltage range	198–264V	
DC voltage range (start)	NA	
DC voltage range (operation)	NA	
Nominal current	220mA	
Total Harmonic Distortion (THD)	< 15%	Full load @230VAC
Power factor	0.5C-0.97	Min-load @ 240Vac and Full-load @ 220 Vac
Displacement factor	0.5C-0.97	Min-load @ 240Vac and Full-load @ 220 Vac
Efficiency - Full load	86% (Typ.)	Full load @230VAC
No-load power	NA	
Stand-by power	< 0.5W	
Protection class	II	
Inrush current	10 A / 80 us	
Max.units per circuit breaker	Type B , 10A MCB	18
	Type B , 16A MCB	29
	Type C , 10A MCB	23
	Type C , 16A MCB	36
Earth leakage current	NA	
Output	Nominal voltage range	
	350mA	10-54 Vdc
	450mA	10-54 Vdc
	500mA	10-54 Vdc
	600mA	10-54 Vdc
	700mA	10-54 Vdc
	800mA	10-50 Vdc
	900mA	10-44 Vdc
	1000mA	10-40 Vdc
	1050mA	10-38 Vdc
	Maximum voltage	60 Vdc
Nominal current range	350-1050mA	DC Output with adjustable constant current from 350 to 1050 mA via NFC in 1mA steps
Current accuracy	± 5%	
Typical output LF current ripple	± 5%	Low Frequency< 120Hz Full load @230VAC

	Item	Value	Remark
<b>Output</b>	Starting time	< 0.5 S	Full load @230VAC
	SVM	$\leq 0.4$	Full load @230VAC
	P <sub>stLM</sub>	$\leq 1$	Full load @230VAC
	Nominal power range	3.5-40W	
	Maximum power	40W	
<b>Dimming</b>	Dimming control	DALI/Touch Dim	
	Dimming range	1-100%	
	Lowest dimming current	0.5%-2%	@ V <sub>o</sub> =35Vdc
	Dimming technique	Amplitude	
	PWM frequency	NA	
	Galvanic isolation	Basic insulated to PRI and double insulated to SEC	
<b>Environment</b>	Ambient temperature range t <sub>a</sub>	-20°C - +35°C	
	Maximum case temperature t <sub>c</sub>	85°C	
	Max. case temp. in fault condition	110°C	When operating under fault conditions, the temperature of the enclosure at any location should not exceed 110 °C
	Storage temperature range	-40°C - +85°C	
	Relative humidity	10% - 95%	
	Surge transient protection	1 kV	L/N
	Environmental rating	Indoor	
	IP rating	IP20	
	Mains switching cycles	>100,000	
	Expected lifetime	> 50,000 h, t <sub>c</sub> 85 °C @ t <sub>a</sub> 35 °C	0.2 % / 1,000 h failure rate
	<b>Packing</b>	Gross weight/box	7.0 kg
Net weight/box		6.0 kg	
Pcs/box		35 PCS	
Dimension/box		385(L)*310(W)*260(H)mm	
<b>Protections</b>			
Short-circuit Protection	Auto recovery		
Open-circuit Protection	Auto recovery		
Overload Protection	Auto recovery		
<b>Conformity &amp; Standards</b>			
Safety standard:	EN 61347-1, EN 61347-2-13, EN 62493		
Performance:	EN 62384		
EMC standard:	EN 55015, EN 61000-3-2, EN 61000-3-3, EN 61547		
SAA standard:	AS/NZS 61347.1, AS 61347.2.13		
DALI protocol standard:	EN 62386-101, EN 62386-102, EN 62386-207		
<b>Cable information</b>			
<b>SEC</b>	+	-	
Cable cross-section	0.34-0.5□/AWG 22-20	0.34-0.5□/AWG 22-20	
Stripping	9mm	9mm	
<b>Terminal information</b>			
<b>PRI-Contact metal</b>			
<b>SEC-Push button/Angled Entry</b>			
<b>DALI-Contact metal</b>			
*Subject to change without notice, HEP guarantees all products perform functionally well*			
* If not mentioned, all the test conditions are based on full load at 230VAC input (for 220-240 VAC input).			

## Current adjustable

### NFC Reader (optional)

Feature:

Easily on-line read a output current from a driver or write a new current data to a driver throughout HEP NFC reader within few seconds.



### APP NFC

Feature:

Quickly check output current of a LED driver simply via Android smart phone, as well as, correct or setup a new current data immediately with no extra equipment at any job site.

### ICON



### Main



### QR Code

Google play



APK



Android 6.0 Up

Smart phone with a NFC function

## Electrical Values

Output Power Range

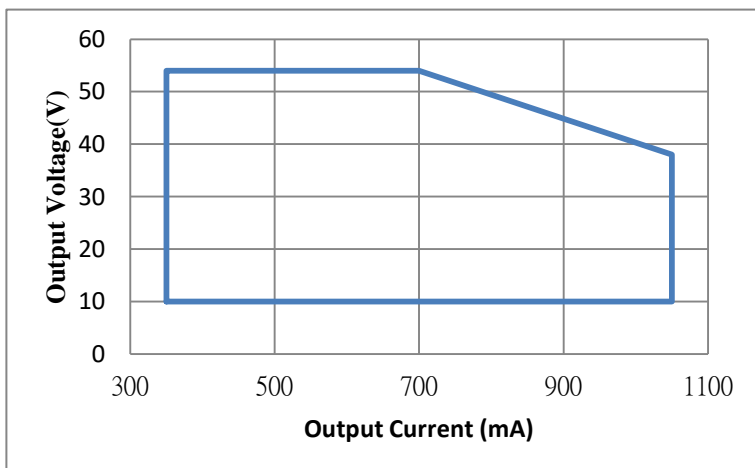

Output Current (mA)	Output Voltage Range (V)	Output Power Range (W)
1050	10-38	10.5-40.0
1000	10-40	10.0-40.0
900	10-44	9.0-40.0
800	10-50	8.0-40.0
700	10-54	7.0-37.8
600	10-54	6.0-32.4
500	10-54	5.0-27.0
450	10-54	4.5-24.3
350	10-54	3.5-18.9

\* Upon client's special demand, customized current range in between 350 mA and 1050 mA could be specified as factory default from shipment. This default current range available revised again via NFC reader program at client's site, if necessary.

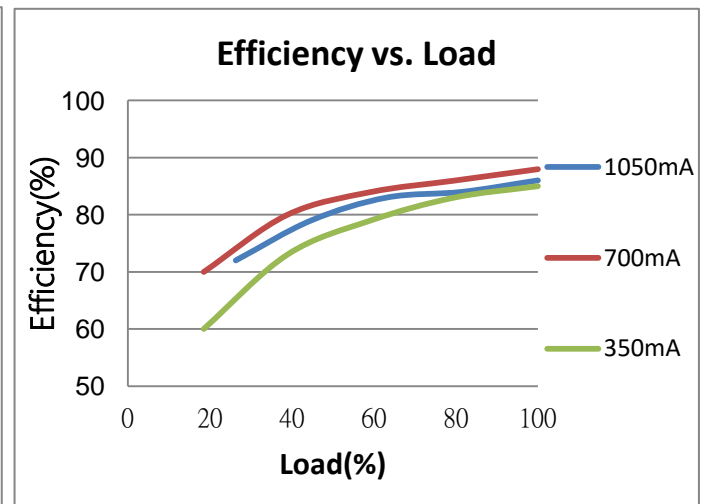
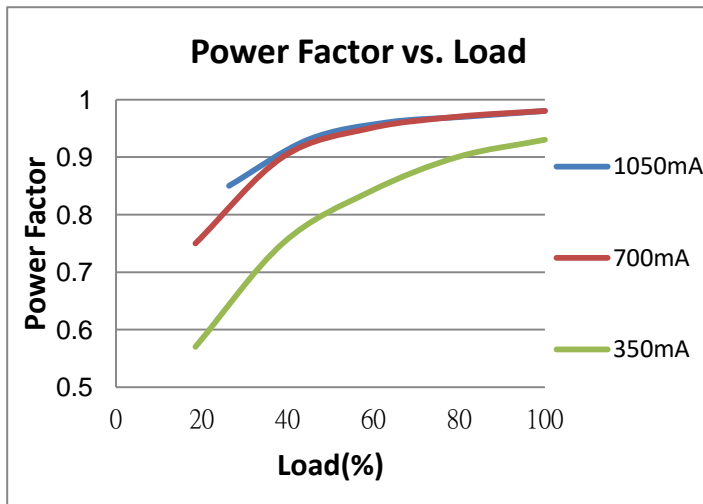
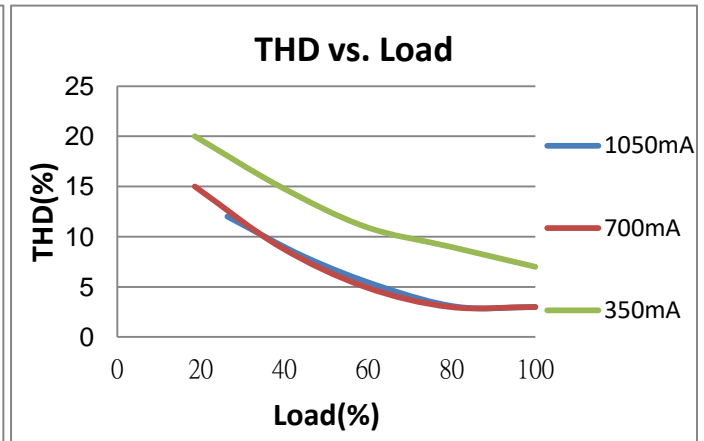
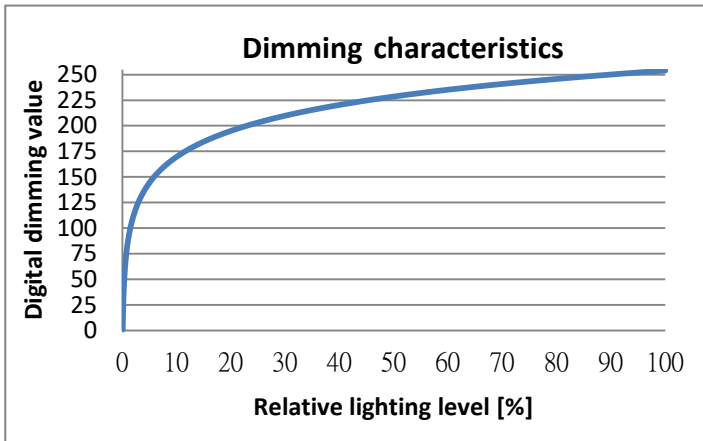

## Label

<b>HEP GROUP®</b> HEP GmbH - Ramsloh 10 58579 Schalksmühle - Germany UN= 220-240V IN= 220mA max. $\lambda = 0.5\text{C}-0.97$ fN= 50-60Hz ta= -20°C - +35°C	<b>DALI LED Driver</b> <b>LWDC40W1050NLR</b> Urange= 10-54 Vdc Irated= 350-1050mA const. Prated= 3.5-40W max. ratings Uout= 60V max. for output details see datasheet	SEC SELV t <sub>c</sub> = 85°C	GMA-513600 05 CE UK CA DALI	Top side NFC)) 9mm wire preparation 0.34-0.5□/AWG 22-20

## Physical Parameter

L : 255.0 mm    W1 : 33.0 mm  
 W : 31.0 mm    W2 : 41.5 mm  
 H : 45.9 mm    H1 : 43.4 mm  
 N : 13.7 mm    M : 136.2 mm  
 K : 27.5 mm

Tolerance :  $\geq \pm 1$  mm  
 Housing Material : Polycarbonate

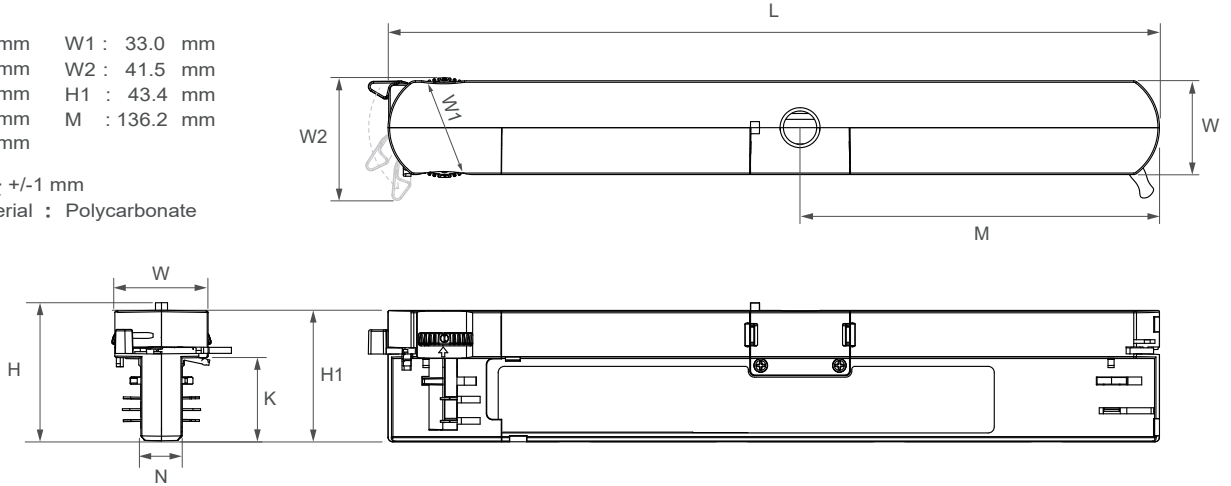

## Wiring Diagram DALI

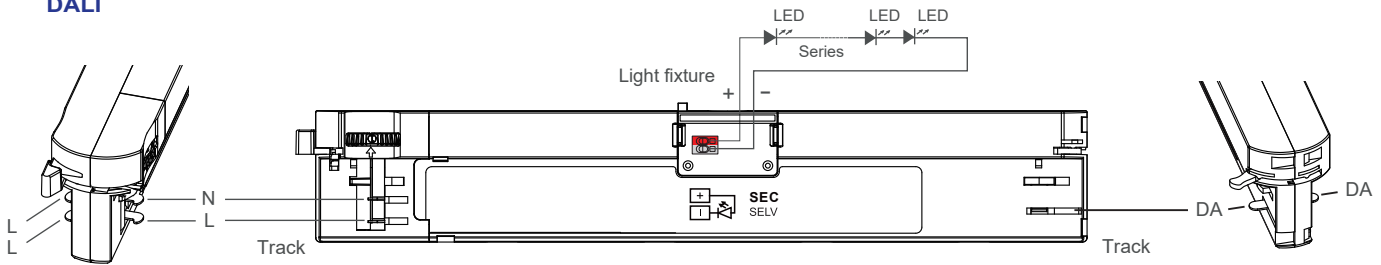

## Touch Dim

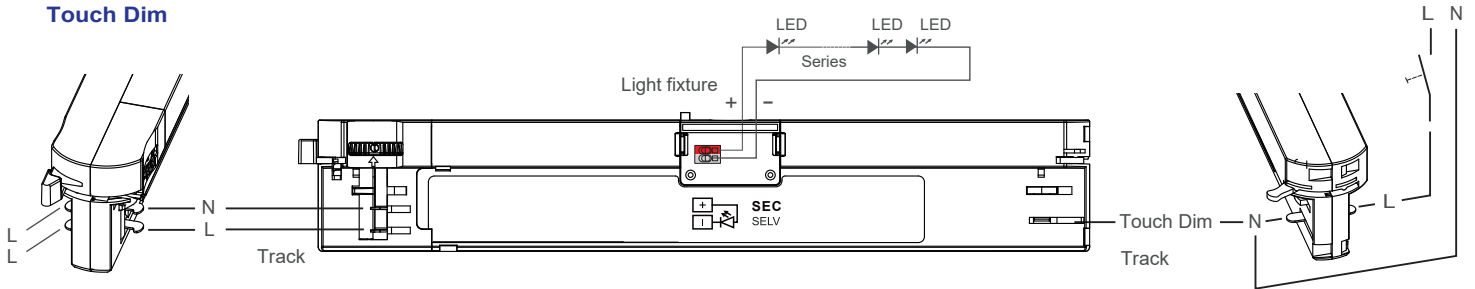

## NFC Antenna Location

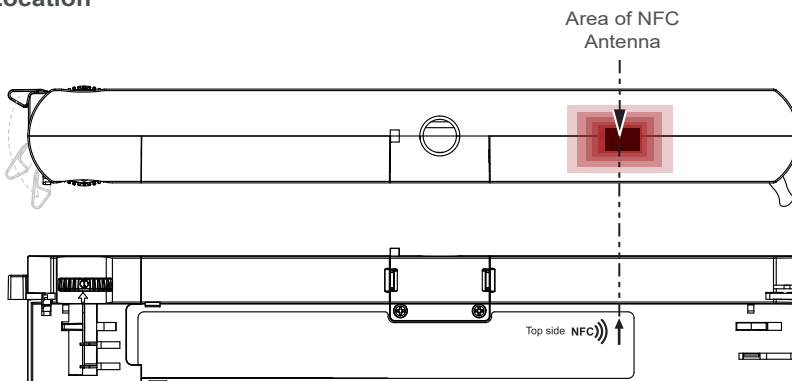

**Lamp screw type**

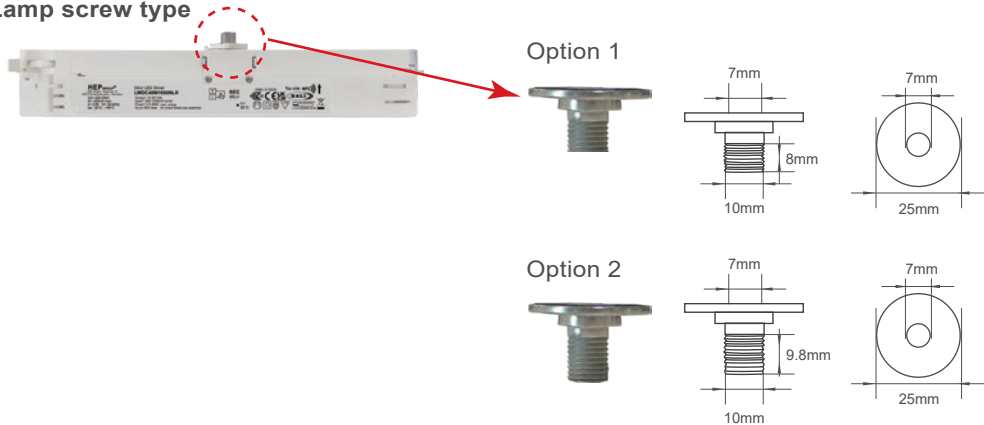

**Load-bearing : 50N(11lbs)**

The driver could be compatible with Global, Powergear, STUCCHI on 3-phase-circuit track system.

Manufacturer	Type	Model	System
NORDIC ALUMINIUM	Global Track pulse DALI	XTSC 6x00 XTSCF 6x00 x=1,2,3,4	3-phase + DALI
STUCCHI	Three-Phase Track + Control System	9000-.../...-ST 9000-.../...-R	3-phase + DALI
POWERGEAR	3 Circuits DALI Track System	PRO-06x0,06400 PRO-06x0,R6400 x=1,2,3	3-phase + DALI

**MECHANICAL LOAD DIAGRAM**

